

EPC - FUSION BONDED EPOXY COATED CAST IRON HUBLESS SHORT PIPE WITH ACCESS DOOR



COMPLY WITH EN877:2010 01

COATING CHARACTERISTIC

Fittings:

Epoxy fittings inside and outside: Fusion bonded epoxy coating.

Coating Thickness: Min- 240µm

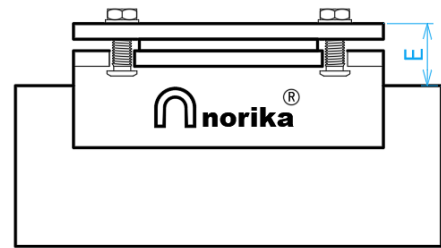

SIDE VIEW

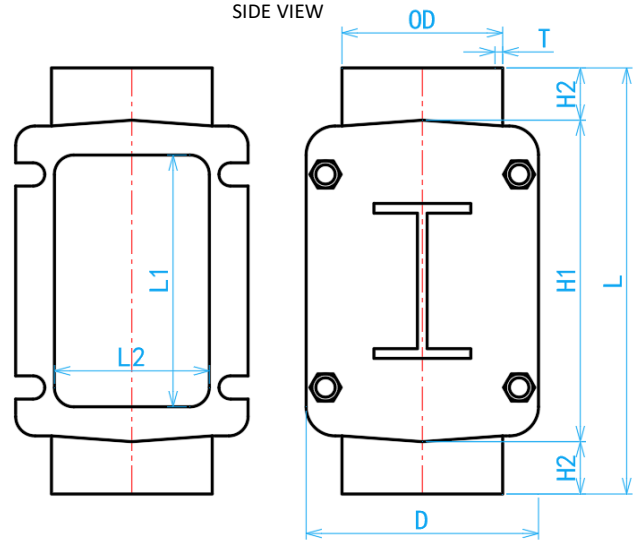

Remove Cover

FRONT VIEW

*Open the inspection cover seal and manually clear any blockage through the wide access door for easier maintenance.

DIMENSIONS

| SKU | DN (mm) | OD (mm) | E (mm) | L (mm) | L1 (mm) | L2 (mm) | H1 (mm) | H2 (mm) | D (mm) | WEIGHT (kg) |
|-----------|---------|---------|--------|--------|---------|---------|---------|---------|--------|-------------|
| HUBESP100 | 100 | 110 | 21 | 340 | 195 | 100 | 225 | 58 | 160 | 7.52 |
| HUBESP150 | 150 | 160 | 21 | 395 | 245 | 150 | 275 | 60 | 216 | 12.80 |
| HUBESP200 | 200 | 210 | 21 | 465 | 292 | 196 | 315 | 75 | 264 | 19.80 |
| HUBESP250 | 250 | 274 | 28 | 575 | 338 | 258 | 380 | 97 | 330 | 38.00 |

Notes: The tolerance for Weight is $\pm 10\%$.